

Application of ALPHA6600 Inverter in the Water Supply System

I. Instruction

Wuyishan is a famous scenic area in China, and the Wuyishan Water Plant plays a significant role in the citizens' lives of Wuyishan City. This water plant was built a very long time ago, and during its operation, bursting pipes and failure of the booster pump were frequent, and sometimes, it even cut off the water supply and had abnormal water pressure, which caused significant inconvenience to the lives of local people. Therefore, this water plant needs urgent technological transformation.

The booster system of this water plant consists of two levels. The first level consists of two booster pumps, one of which is driven by a 93KW motor and the other by 45KW motor as the replenishment and spare pump. The technological transformation has adopted frequency-conversion constant-pressure control system, the system conducts sampling of the pressure of the water supply pipe network, the operating number of the pump units is automatically adjusted in accordance with the water consumption to complete closed-loop control of the pressure of the water supply, and when there is a change of flow in the pipe network, it can stabilize the pressure of the water supply and realize conservation of electric energy. The control goal of the system is the discharge pressure of the header pipe in the pump station. The set value of system feed pressure is compared with the actual value of feedback pressure of the header pipe, the difference is input into the CPU for calculation and processing, the control instruction is sent, the output of the inverter is controlled to control the motor rotation speed of the main booster pump, and the input and cutting of the replenishment pump is controlled to stabilize the pressure of the main feed pipe at the set pressure value.

II. Configuration and System Principle of the Wuyishan Water Supply System

1. System Scheme Framework

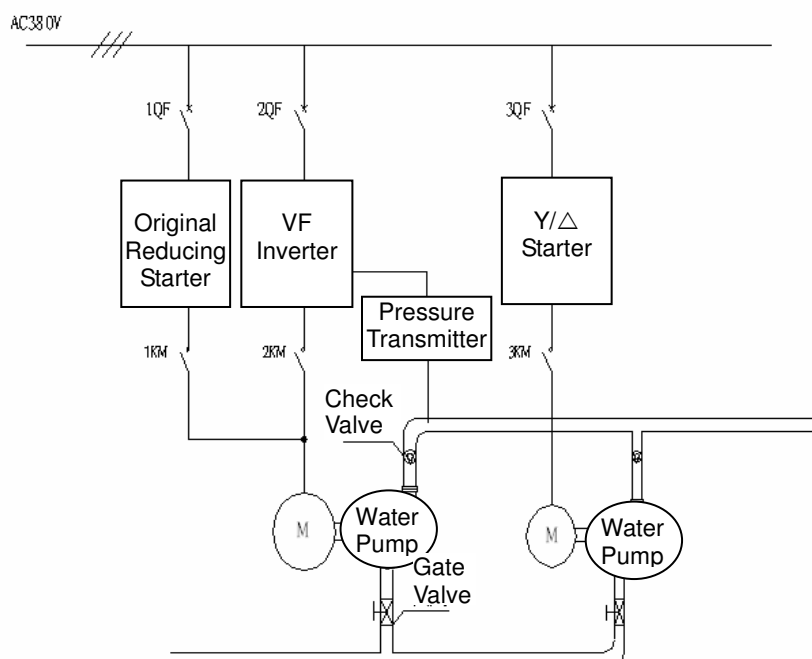

2. System Configuration

The ALPHA6600 P model inverter has a built-in PID regulator. The pressure transmitter instantly detects the pressure of the header pipe and transforms it into 4-20 mA current signal, then, it directly sends it to the simulation current input port on the inverter and sets the pressure value and PID parameter, and after calculation through the built-in PID, it controls the output frequency. The system parameters can be adjusted during actual operation to make the system control and response more complete. For example, different pressure values can be set for different time intervals, which does not only save energy but can also better satisfy the end user's requirement of water pressure.

One ALPHA6600-3093P inverter;

One pressure sensor (measuring range: 0~10 kg/cm², input: DC24V; output: 4~20mA); one control cabinet (including one set of original autotransformer starter, one set of Y/ Δ starter and instrument light, contactor).

3. System Function

a. "Dormancy" Function

During system operation, when the users have small or no (such as at night) water consumption, in order to save energy, this special system has been equipped with a "dormancy" function which can suspend the operation of the water pump. When the output frequency of the inverter is lower than its lower limit, supply to motor of the spare pump will stop; when the output of the inverter is at the lower limit frequency, but the actual water pressure of the header pipe is still higher than the setting, after operating for a while, the inverter enters "dormancy mode" and stops operating; when the water pressure of the header pipe decreases to be below the set value, the inverter is awakened to reenter the PI regulation state. The "dormancy confirmation time" is built in the inverter, and when the output frequency of the inverter is lower than the time value of dormancy, such as lower than the dormancy confirmation time t_d , i.e., $t_d < t_n$, the inverter continues to work; when $t_d > t_n$, the inverter enters the dormancy mode. During the peak of water consumption, when the output frequency of the inverter reaches the upper limit frequency, the replenishment pump will be started.

b. Power Frequency/ Variable frequency Switch Function

There is a high requirement of stability for the water supply system at the water plant. Once there is a failure, it will affect the domestic water use of the whole city. Therefore, this system has been installed with a power frequency/Variable frequency switch function. In normal situations, the system is under the frequency-conversion constant-pressure water supply state, but once there is failure or routine maintenance of the inverter, it can switch to the power-frequency operation immediately, and the original spare autotransformer start system is

used to start the water pump to ensure continuance of water supply, and the reliability of the whole system can properly satisfy the requirements of the users. The two start systems are electrically interlocked to prevent mal-operation and ensure safe operation of the system.

c. Automatic Switch of the Replenishment Pump

When the frequency-conversion operation of the main pump reaches 50HZ, after delay for 3 minutes, the replenishment pump will be automatically be put into use to replenish pressure. In this way, pressure of the system pipe network during peak water consumption can be ensured, and the operating frequency and current of the main pump can be reduced as well; when water consumption of the system decreases, and the operating frequency of the main pump decreases to the lower limit of 20HZ, the replenishment pump will be cut off to increase the operating efficiency of the main pump. In this way, the whole system can operate under an energy-efficient and optimized state.



III. Parameter Setting of the Inverter

Function Code	Set Value of Parameter	Function Instruction
P0.04	1	Led by the terminal, control the operation and stop of the inverter
P0.01	9	Frequency is set by the PI regulator
P0.09	20	Set the lower limit frequency of the pump operation
P2.06	3	Improved motor noise, but the set capacitance is too high, and electric leakage is increased.
P1.05	1	Acceleration mode of the motor
P7.09	0.2	Deviation setting of the PI regulator
P7.05	1	Proportion of the PI regulator
P7.06	10	Integration of the PI regulator

IV. Benefits for the Users

1. Increase the service life the equipment and the pipe network, and reduce the maintenance workload of the system.

Due to adoption of the frequency-conversion constant-pressure control, the water pump has adopted a soft start to eliminate damage to the motor from impact torque during the starting of the big motor. During the start, the impact on the water pump is significantly reduced, and in the meantime, due to the soft start and constant-pressure control of the water pressure, the water hammer effect on the pipe network during the start is eliminated, and the phenomenon of bursting pipes won't happen again. In this way, the service life of the original equipment is greatly increased, the failure rate is significantly reduced, and maintenance workload of the subsystem is also reduced.

2. Improve the quality of water supply, and increase the reliability of the whole system.

Since the adoption of the frequency-conversion constant-pressure control system, the pressure of water supply can be regulated smoothly, and the watch-stander can have a more stable and flexible regulation and control of the system. With the development of urban pipe networks and changes in the volume of water supply, the pressure of water supply can be regulated conveniently. Since adoption of the new system, the failure rate has been significantly reduced, and the two start systems can compensate each other to ensure the continuance of system water supply and provide reliable guarantee for the cost effective and optimized system operation.

3. Improve the power utilization situation in the water plant.

Since the adoption of the frequency-conversion soft start, the impact on the power system during the start of the previous start system has been eliminated. The power factor of the new system can reach 0.95, its efficiency can reach 0.98, the system operating current is significantly reduced, the line loss is also greatly reduced, and the tense electricity available in the water plant has been improved.

4. Significant energy efficiency and impressive economic benefits

During the operation of the previous system, with changes in water consumption, it required manually switching and replenishing the pump operation, and the pressure of the pipe network fluctuated with changes in the water consumption, usually between 3.8~7kg/cm². The optimum water supply pressure of the system is around 4.0kg/cm², and there tends to be bursting pipes when it exceeds 7kg/cm². We know the pressure H is in proportion with the square of the rotation speed of the motor N , and the shaft power P is in proportion with the cube of the rotation speed of the motor N , i.e., $H \propto N^2$, $P \propto N^3$. When water consumption is minimum and only the replenishment pump is used to provide pressure, the pressure of the previous system is about 7kg/cm²; when frequency-conversion system is used to provide pressure, the pressure can be controlled at around 4.0kg/cm², and this time, the power efficiency can reach 57%; if it operates under the lower limit frequency for a long time, the inverter can also operate under the "dormancy mode", and in general, the whole system can have a power efficiency of around 40%. The system has a significant energy conservation effect, and in accordance with local electricity prices, the electricity costs saved in seven months can recover the initial investment, and the economic benefits are impressive. It can also reduce the work intensity of the watch-stander, and after transformation of the original system, the replenishment pump can switch automatically and the watch-stander does not have to worry about bursting pipe accidents caused by untimely switch of

the replenishment pump.

